

ARX 23-2C

LIGHT TANDEM VIBRATORY ROLLER

EU Stage IIIA / U.S. EPA Tier 4 Interim



WORKING AROUND OBSTRUCTIONS

The Ammann ARX 23-2C Light Tandem Roller makes it easier to see – and work – near obstructions. It also offers a drum in front and tyres in back to provide both compaction power and the sealing effect of pneumatic rollers. The roller features a new articulation joint that enables quick drum adjustment from in-line to offset configurations, helpful when working close to obstructions. Operators need watch only one drum, knowing the second will be a safe distance from the obstacle. The in-line drum setting is available when it's time for productivity in open spaces.

APPLICATIONS

- Small and medium construction sites
- City roads
- Boardwalks
- City street repairs
- Road maintenance

PRODUCTIVITY

Electronic drive lever

Advanced drive control enables smooth starts and stops during machine operation.

Articulation joint with oscillation

Great manoeuvrability and constant contact with the surface are key factors in achieving high quality compaction.

Sprinkling system

Multi-level filtration system with large water tank for extended intervals between fillings.

ERGONOMICS

Operator platform design

Spacious operator platform with comfortable driver's seat.

Simple & convenient operation control

Dashboard with clear display and intuitive machine control.

Exceptional operator visibility

Perfect all-around machine visibility to maximise safety on the jobsite.

SERVICEABILITY

Tool-free daily inspection

Quick and easy daily inspection.

Maintenance-free parts

Reduce time required for machine maintenance and prevent damage to components.

Service point locations

Service and regular maintenance points are quickly and readily accessible.

MAXIMUM RECOMMENDED COMPACTED LIFT THICKNESS AT OPTIMAL WORKING CONDITIONS

	Sand / gravel	Mixed soils	Silt	Clay	Stabilisation	Asphalt
ARX 23-2C	220 mm (8.7 in)	150 mm (5.9 in)	–	–	100 mm (3.9 in)	80 mm (3.2 in)

AMMANN

TECHNICAL SPECIFICATIONS
ARX 23-2C LIGHT TANDEM VIBRATORY ROLLER
EU Stage IIIA / U.S. EPA Tier 4 Interim

DIMENSIONS

A	MACHINE LENGTH	2500 mm (98.4 in)
B	WHEELBASE	1755 mm (69.1 in)
C	MACHINE HEIGHT	2550 mm (100.4 in)
D	MACHINE HEIGHT (FOLDED ROPS)	1935 mm (76.2 in)
E	DRUM WIDTH	1000 mm (39.4 in)
G	MACHINE LENGTH	2585 mm (101.8 in)
H	GROUND CLEARANCE	280 mm (11 in)
H1	SIDE CLEARANCE	490 mm (19.3 in)
I	DRUM DIAMETER	695 / 635 mm (27.4 / 25 in)
J	DRUM SHELL THICKNESS	13 mm (0.5 in)
K	MACHINE WIDTH (TOTAL)	1120 mm (44.1 in)

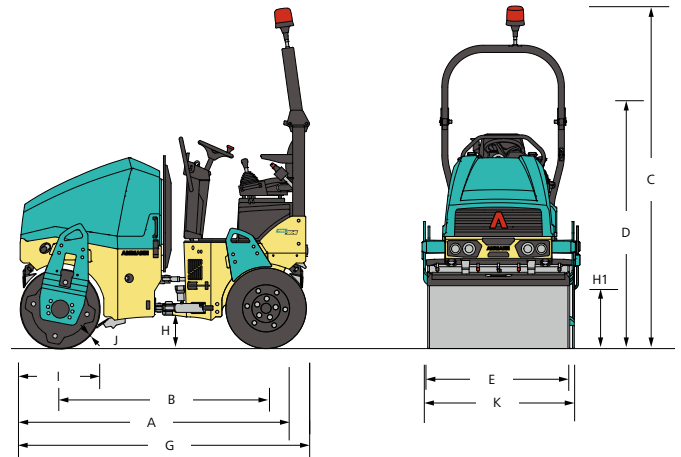

WEIGHT & OPERATING CHARACTERISTICS

OPERATING WEIGHT	2110 kg (4652 lb)
OPERATING WEIGHT MAX.	2310 kg (5093 lb)
STAT. LIN. LOAD	10.7 kg/cm (23.6 lb/in)
TURNING RADIUS INSIDE	2630 mm (103.5 in)
STEERING / OSCILLATING ANGLE	30/6.5 ±°

ENGINE

ENGINE TYPE	Kubota D1803-M-DI
EMMISSION CLASS	EU Stage IIIA / U.S. EPA Tier 4i
POWER OUTPUT ISO 3046	24.8 kW (33.3 HP)
CYLINDER / LTR.	3 cyl / 1826 cm ³
1. / 2. WORKING SPEED	2100 / 2400 rpm
TRAVEL SPEED	11 km/h (6.8 MPH)
GRADEABILITY WITH / WITHOUT VIBR.	35% / 35%

STANDARD

- Front and rear drive / front vibration
- Pressurised pulse interval sprinkler system
- Anti-adhesive sprinkling circuit
- 2 working frequencies
- Control system with emergency stop
- Ammann Vibration Control
- Lateral sliding seat
- Hydraulic test ports
- Off-set into in-line drum setting
- Battery disconnection switch
- On-board diagnostics
- Front/rear rubber bumpers

COMPACTION FORCES

AMPLITUDE I	0.5 mm (0.02 in)
AMPLITUDE II	0.5 mm (0.02 in)
FREQUENCY I	58 Hz (3480 vpm)
FREQUENCY II	66 Hz (3960 vpm)
CENTRIFUGAL FORCE I	33.4 kN (7508 lbf)
CENTRIFUGAL FORCE II	39.9 kN (8970 lbf)

MISCELLANEOUS

BATTERY / CAPACITY	12/77 V/Ah
WATER TANK	190 l (50.2 gal)
ANTI-ADHESIVE TANK	12 l (3.17 gal)
HYDRAULIC TANK	28.5 l (7.5 gal)
DIESEL FUEL TANK	35 l (9.2 gal)
NUMBER OF WHEELS	4
TIRE SIZE	205 / 60-R15

OPTIONAL EQUIPMENT

- CE-kit with folding ROPS and working lights
- Road lights
- Infrared thermometer
- ACE^{force}
- ATC - Ammann Traction Control
- Reverse alarm
- Additional working lights (ROPS mounted)
- Warning beacon
- Second drive-lever, left
- Arm rests
- Edge-cutter inc. Multi-function lever
- Scrapers tiltable
- Bio-degradable hydraulic oil
- Central lifting point
- Customer color
- Weather canopy
- Servicelink